

DIFFUSER DESIGN AND RIVER MODELING

Paul D. Christiano and Daniel M. Loudermilk

AUTHORS: Dames and Moore, 455 East Paces Ferry Road, Suite 200, Atlanta, Georgia 30363.

REFERENCE: *Proceedings of the 1991 Georgia Water Resources Conference*, held March 19 and 20, 1991, at The University of Georgia, Kathryn J. Hatcher, Editor, Institute of Natural Resources, The University of Georgia, Athens, Georgia.

INTRODUCTION

Permitted wastewater discharges from industrial facilities are required by state and federal environmental regulations to assimilate into the receiving stream within a reasonable distance downstream of the discharge. Diffusers are currently the most common device employed to achieve this assimilation. This paper will explore diffuser Point of Discharge (POD) selection, design methodology, the use of diffusers for various discharge scenarios.

Ideally the diffuser should be designed to maximize near-field dynamic mixing under a variety of stream and production water flow rates. The physical configuration should be such that it can be constructed and installed in a timely and cost effective manner. Analytical modelling should be employed to assess the design's effectiveness in reaching adequate dilution within the mixing zone defined by the regulatory agencies. The physical characteristics of the diffuser manifold can vary greatly depending on the particular needs of the operator. A desirable diffuser will have a single or multiple ports sized such that the effluent discharge exits the port at a relatively high velocity during all expected flow rates. This high momentum of the discharge relative to the receiving water causes the discharge stream to entrain ambient water into the jet plume in the "near-field." The objective in the near-field is sufficient ambient water entrainment prior to the loss of jet momentum to prevent the persistence of slug flow and/or significant wastewater/ambient flow density differential in the "far-field."

The horizontal and vertical angles of the ports as well as the configuration of the port itself are also critical components of design. The density of the effluent relative to the ambient water body is one of the most important determining factors in the configuration and orientation of the diffuser ports. In addition to the characteristics of the wastewater stream, the physical constraint imposed by both the river morphology and the regulatory constraints must be taken into account. These include river bathymetry, stream bottom structure (sand or rock), stream flow variability, allowable mixing zones, and in-stream toxicity limits. This paper presents a review of the analytical methods for assessing in-stream diffusion characteristics as well as design alternatives for accomplishing effective in-stream assimilation.

DIFFUSER POINT OF DISCHARGE (POD) LOCATION

The long-term effectiveness of a diffuser system will be governed by the geomorphology of the river at the point-of-discharge (POD). One of the most important non-technical factors is cooperation, or lack of cooperation, by the owner of the land which a diffuser line must cross to get to the desired POD. Another important factor which should be considered is ease of access to the river, as well as POD proximity to treatment systems. Given the monitoring requirements mandated by the governing agencies, long-term maintenance costs can be significantly impacted by sites with poor or limited access.

Physical Conditions

Effective diffusion typically requires discharge pressures in the range of 20 to 50 psi. If the geography of the area is such that significant elevation differences exist, gravity may provide enough pressure for adequate mixing. Otherwise, a pump will be needed to provide the required pressure. To provide maximum flexibility in discharge flow, some means of controlling the pressure at the discharge should be employed. Although elevation differences may allow the elimination of a pump and the associated cost, any savings should be weighed against the risk of insufficient dilution and well-field shut-in should flow rates vary significantly from those expected.

The actual physical conditions of the area are also important. The presence of rock and unstable soils can create anchoring and pipe stability problems, along with concerns regarding erosion and sediment control. Competent hard rock river bottoms in reaches under reservoir control can lend themselves to relatively inexpensive mounting designs consisting of pipe weights. Unstable soft bottoms however, present the problem of maintaining clean discharge points. In such instances the use of pile mountings are generally essential for long-term dependability.

Physical River Characteristics

Detailed bathymetric surveys coupled with soil probes are necessary for determining the underwater contours in the

DIFFUSION ANALYSIS METHODOLOGY

vicinity of the POD. This information can be used to make several important determinations. The river cross section, as established by the survey, will determine the exact location of the diffuser. The contours will also show features which may not have been expected, such as sandbars or depressions in the river bottom. In addition, probing will indicate the prevalence of bottom debris which is a specific problem in reaches controlled by reservoirs. Design criteria which can be obtained from survey results include the bottom slope, the depth of competent material, the bed material stability, and the river velocity at the specific site.

The river cross section can also be used to predict the location of eddies and sinks, situations which should be avoided when locating a diffuser. When combined with historical flow data, the cross section can be used to predict local flow patterns and velocities.

The bottom material should also be analyzed prior to final POD selection. Construction can be greatly hampered if unexpected conditions are encountered which require design changes.

The actual POD location characteristics are of notable importance. However, the general river characteristics can have greater significance with respect to the diffuser design. The areas of the river up and down stream of the POD should be looked at both on available maps and in the field. If the river width is greater or more narrow upstream than at the POD site, or any notable bends in the river alignment occur, the localized water velocity will be affected, which, in turn affects the efficiency of mixing. The inside of a river bend usually has relatively slower velocities than the outside. The slower velocities can lead to sediment deposits which can cause fouling of a diffuser.

Historical River Characteristics

Historical flow data should be used to statistically estimate flow parameters including yearly average flows, monthly average flows, and 7Q10 flows. Certain physical changes must also be investigated. For example, if 50 years of historical flow data exists for a given gaging station near a POD, and a lock and dam, or reservoir has existed upstream of the gaging station for only 35 years, then only the flow data for the past 35 years should be used in a statistical analysis.

Statistical analysis of historic flow data is valuable for determining specific flow characteristics, however other useful information exists in historical data. Relative maximum and minimum flows can be researched for recent periods of flooding or drought. This knowledge can be used as a yardstick to predict expected high or low flows in terms of "real events" which were likely witnessed by either the designer or the operator. This information is necessary for establishing the design criteria for plume vertical travel during low flows as well as plume stratification during high flows.

The objective of modeling a proposed diffuser is simulation of the spread and mixing of the wastewater in the receiving river. The flow and mixing characteristics of the affected river reach are influenced by time variant stream flows and the relative densities of the effluent and river water. Most simulation models presently used are intended to predict the dilution of the effluent due to turbulent mixing in the near-field mixing zone.

The distribution of constituents and contaminants from a wastewater discharge within the receiving river is a function of the hydrodynamic variables of the discharge and the receiving water body. The effluent distribution in the vicinity of the discharge can take several forms, such as surface spreading of the more buoyant effluent with minimal mixing and extensive jet mixing of the effluent with the receiving water. The diffuser design as discussed in this paper creates a jet velocity that impinges on ambient velocities.

Under the aforementioned diffuser criteria, the velocity field of the water body is influenced by the velocity of the effluent. The dilution of the discharge is due to the entrainment of ambient water into the jet as it spreads laterally and vertically. The desired modeling results show the concentration of the effluent by the time it reaches the legal mixing zone is sufficiently diluted to be virtually indistinguishable from the ambient waters.

At the edge of the near-field mixing zone, dilution due to advection, convection, and diffusion begins to dominate. The hydraulics governing "far-field" mixing are extremely complex. Far-field modeling requires detailing of the hydrodynamics of the system on a near continuous basis as well as identification of the density gradients within the river. The EPA approved Cormix 1 model (as described in EPA publication EPA/600/3-90/012, "Expert System for Hydrodynamic mixing zone analysis of conventional and toxic submerged single port discharges") predicts both near-field and far-field mixing. Based on the predictions encountered in the past for small discharges into larger rivers, the dilution factor at the edge of the high jet zone is sufficiently high to indicate virtual complete mixing. This high level of dilution can be attributed in part to the extremely low discharge rates relative to a large river flow rate (2-6 cfs discharge vs. 4000 - 8000 cfs river flow rate). Modeling on smaller rivers have also indicated that mixing is sufficient to meet NPDES permit requirements. However, due to the much smaller river flows "virtual complete" mixing is not achieved in the modeling results. Further, for the relatively low tributary flows, wastewater discharge must be carefully controlled due to the low total assimilative capacity.

The EPA approved models to simulate single port and multiport discharges are Cormix 1 and Cormix 2 respectively. These models are used for discharges into flowing unstratified or stratified water environments, such as rivers, lakes, estuaries, and coastal waters. Input is required for ambient conditions as well as effluent characteristics for both Cormix programs.

The modeling results have been shown to be fairly reliable for well established streams with little or no variability. However, this type of stream condition is rare. A modeling effort should utilize the worst case scenario of any design situation (i.e. 7Q10 low flow with maximum effluent discharge) in conjunction with risk factors for exceedance of these conditions. In addition, sufficient adaptability should be built into the diffuser design to allow changes after initial construction to improve efficiency.

DIFFUSER DESIGN/CONFIGURATION

Many factors have an impact on the configuration and location of diffusers. One of the primary limiting factors is the NPDES permit conditions. Individual permits vary, but contain many common restrictions. Such restrictions include, but are not limited to, the limits of the legal mixing zone boundaries and the levels of constituents in the water at the edge of said mixing zone. Diffuser design must provide for mixing of the wastewater with the ambient river water within the legal mixing zone downstream to levels below allowable limits.

As mentioned above, to predict the mixing of wastewater into the receiving waters both near-field and far-field modeling should be employed. The near-field model uses entrainment coefficients, length of zone of flow establishment and velocity, and concentration profiles, all verified by experimental observations. These are used to predict plume size and location with the result being isopleths of concentrations from all jets. The near-field model generally applies to distances of less than 50 feet from the diffuser. Boundary conditions predicted by the near-field model can be taken as source concentrations for the far-field model.

Physical Configuration

Industrial wastewater usually has a density that varies significantly from typical river water. This density difference is compensated for in diffuser design by changing the vertical orientation of the diffuser nozzle depending on whether the density of the wastewater is higher or lower than the receiving stream. The momentum of the high velocity effluent is directed in an upward direction so that when the effects of gravity overcome the momentum, the plume will continue mixing with the ambient water as it moves in a downward or upward fashion in relation to the river bottom. For more dense effluents, if the diffuser port or nozzle were pointed parallel with the river bottom, the heavier wastewater plume would drop to the bottom of the river before maximum levels of mixing could occur. It should also be noted that if the ports are pointed straight up the resulting mixing would not be very efficient because the ambient water would contain partially mixed wastewater falling back towards the diffuser due to the density differential.

The horizontal alignment of diffuser head can be positioned to provide both maximum plume mixing and plume movement downstream. In smaller streams and rivers, diffuser alignment will tend to point in more of a downstream direction so the high velocity plume will not impact one of the stream banks. This will also allow the plume to remain within the legal mixing zone, which is usually one-half of the stream width. In larger rivers the flow and physical river characteristics will dictate the alignment of the diffuser. Some diffusers will be angled partially downstream, while others will operate more efficiently by facing perpendicular to the normal river flow.

The use of an eductor system can significantly enhance mixing efficiencies. An eductor system uses the power of the effluent jet to pull ambient water into the effluent stream at discharge which can produce immediate dilutions of up to 60 percent. The eductor system can be screwed onto the threaded end of a diffuser port (see Figure 1). Each eductor requires a specific field surrounding the port from which to pull ambient water. For this reason, when eductors are used, the ports must be spaced apart from one another to sufficiently allow each eductor to operate efficiently. One configuration which can be used is to place the ports at staggered distances from the shoreline to achieve the desired results.

Diffuser Mounting/Construction

As mentioned previously, the buildup of sediment can cause diffuser fouling. This type of problem can be minimized by placing the diffuser port(s) a safe distance above the existing river bottom, either on a platform, piles, sandbags, or any combination thereof. The mounting selected must consider the specific characteristics of the site geomorphology to avoid plugging or destruction of the diffuser.

The diffuser design should not only consider maximum mixing, but also constructability and cost of construction. A diffuser designed to provide 100 percent mixing well before the plume reaches the legal mixing zone will be of no use to an operator if it's construction cost is prohibitive or it is too difficult to build.

DIFFUSER COSTS

Diffuser costs can range from \$50,000 to well over \$500,000 depending on site access, water depth, and design constraints. In addition, normal operation will require modification to the diffuser as seasonal changes cause stream flow and effluent discharge variations. These changes will be more significant in smaller rivers and streams with greater seasonal variations and thus will raise the maintenance costs. Larger rivers will require less maintenance but will likely have higher initial investment costs due to the sheer size of the water body. Monitoring requirements at discharge points add additional construction and maintenance costs as well as paperwork for agency reporting.

SUMMARY

A good diffuser design is one which will perform well with minimal maintenance once installed, and can be constructed without significant problems. The designer should include within the design criteria the full range of both production water and stream flows. Further, design should be supported with effective analytical analysis of mixing characteristics to provide assurance as to long-term system dependability.

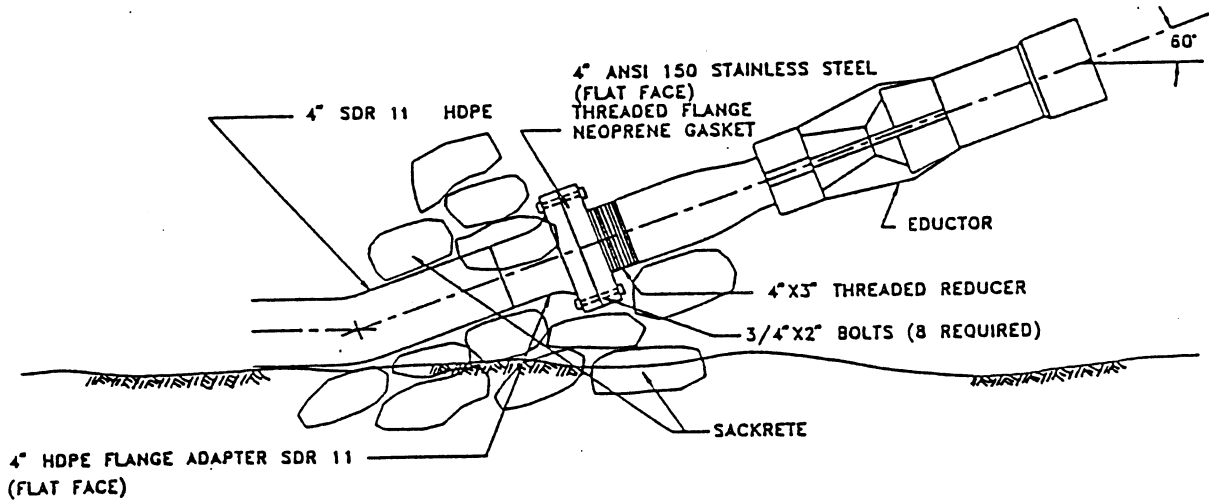

Figure 1. Diffuser Port Cross-Section